

TR SWITCH

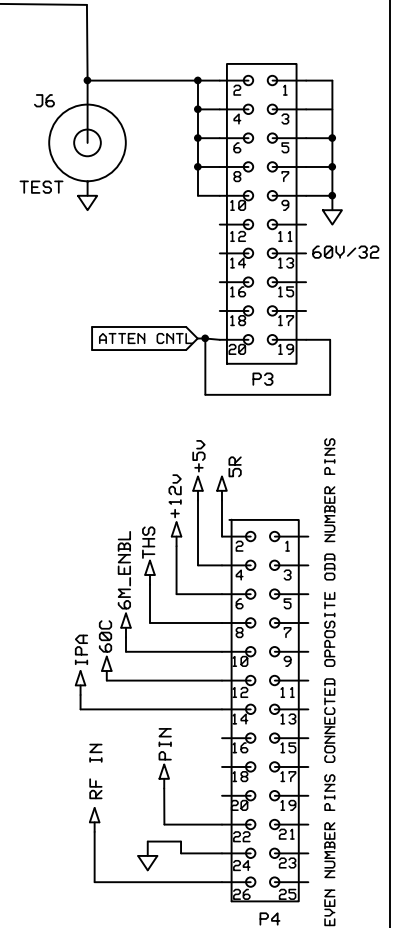

Capacitors in pF

Elecraft		
KPA500 LPF BANK		
Bob Friess	Rev B	Page 1 of 3
	1/30/11	

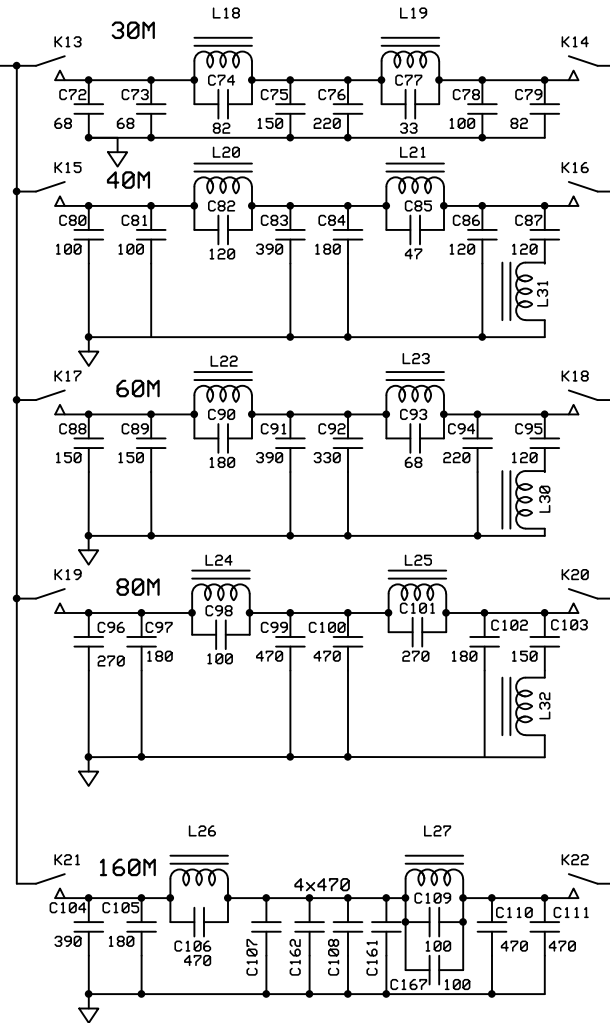
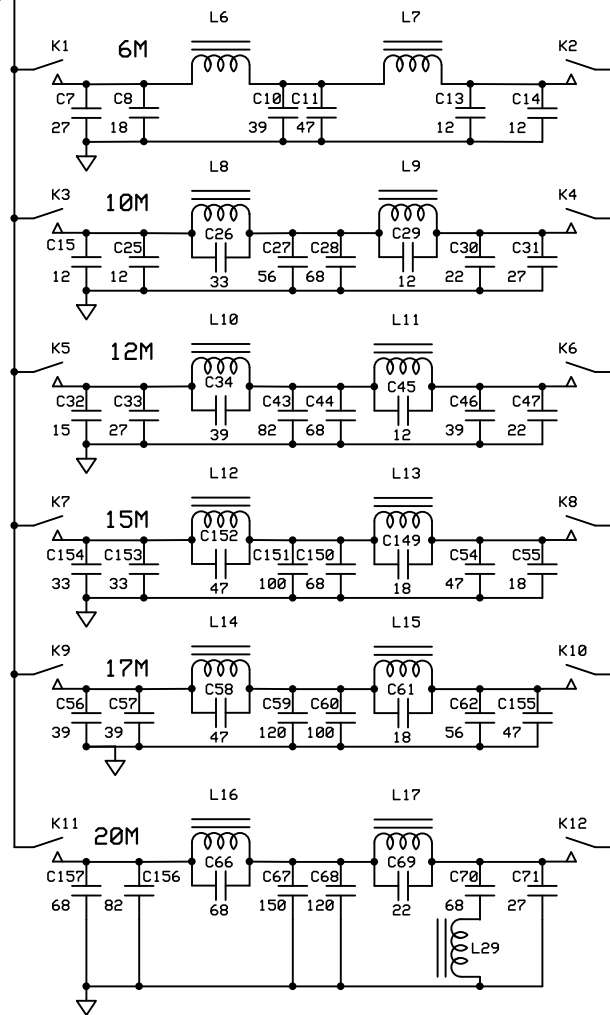
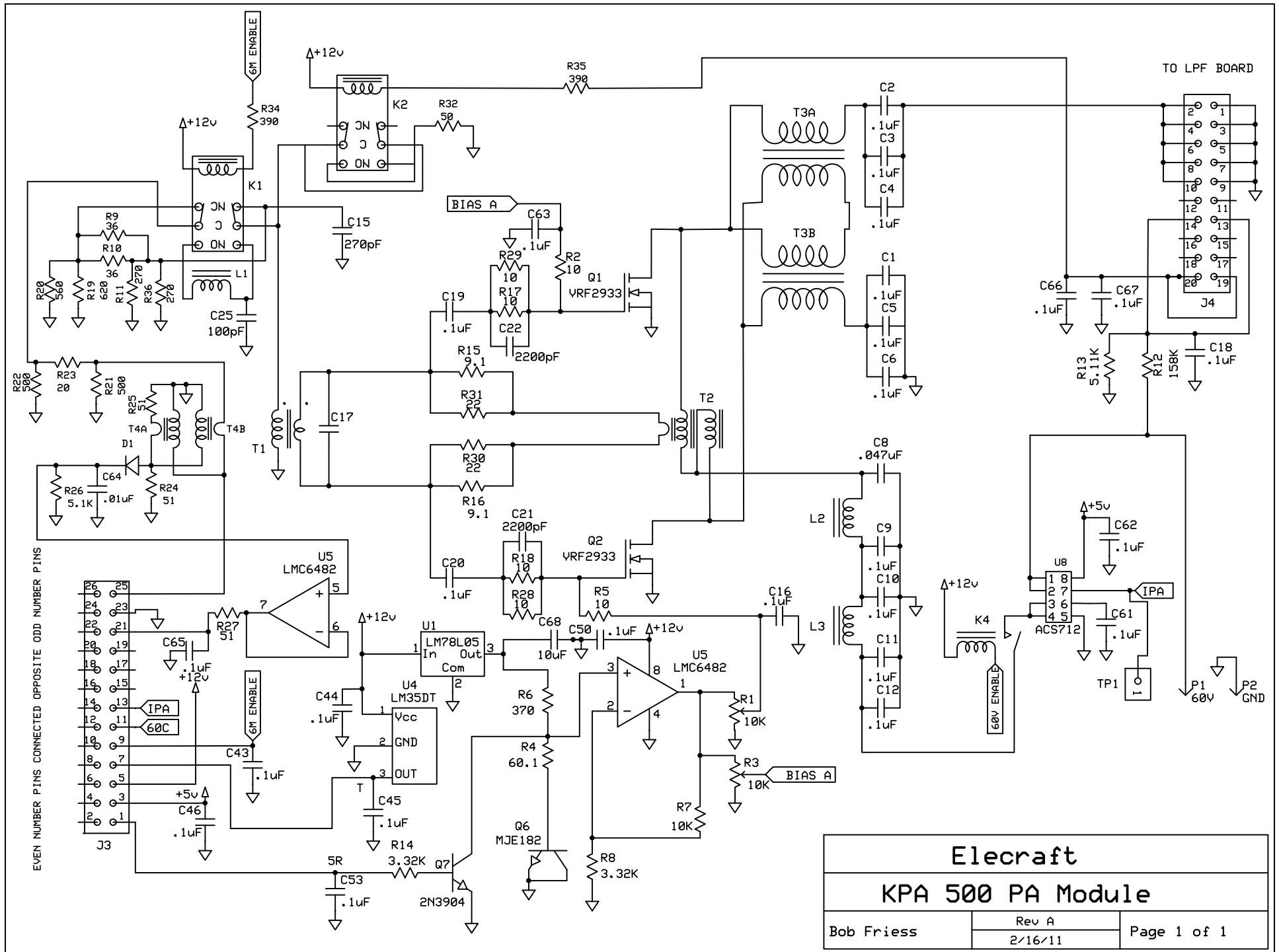

EVEN NUMBER PINS CONNECTED OPPOSITE ODD NUMBER PINS

Elecraft		
KPA 500 PA Module		
Bob Friess	Rev A 2/16/11	Page 1 of 1

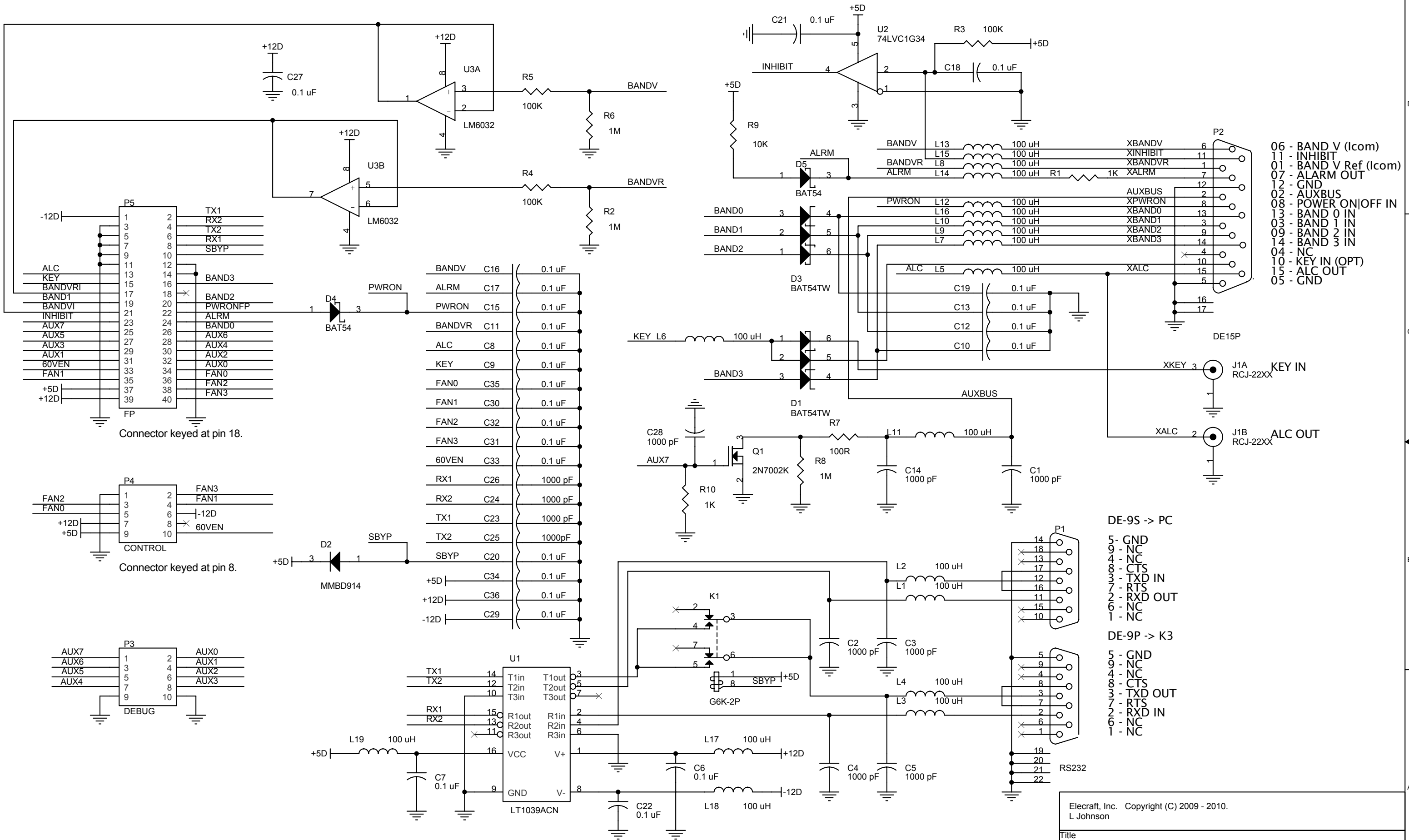

- 06 - BAND V (Icom)
- 11 - INHIBIT
- 01 - BAND V Ref (Icom)
- 07 - ALARM OUT
- 12 - GND
- 02 - AUXBUS
- 08 - POWER ON/OFF IN
- 13 - BAND 0 IN
- 03 - BAND 1 IN
- 09 - BAND 2 IN
- 14 - BAND 3 IN
- 04 - NC
- 10 - KEY IN (OPT)
- 15 - ALC OUT
- 05 - GND

DE-9S -> PC

- 5 - GND
- 9 - NC
- 4 - NC
- 8 - CTS
- 3 - TXD IN
- 7 - RTS
- 2 - RXD OUT
- 6 - NC
- 1 - NC

DE-9P -> K3

- 5 - GND
- 9 - NC
- 4 - NC
- 8 - CTS
- 3 - TXD OUT
- 7 - RTS
- 2 - RXD IN
- 6 - NC
- 1 - NC

Elecrcraft, Inc. Copyright (C) 2009 - 2010. L Johnson		
Title KPA500: I/O Board		
Size B	Document Number 2009112401	Rev C
Date: Friday, February 11, 2011	Sheet 1	of 1

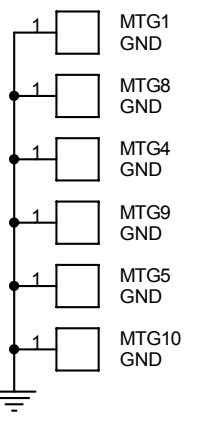
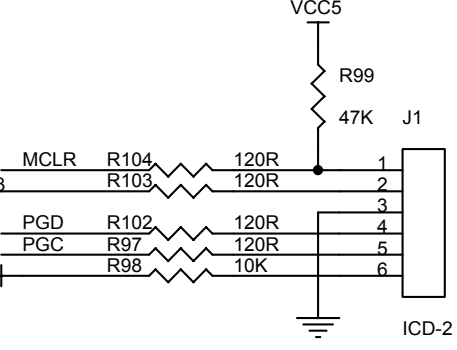
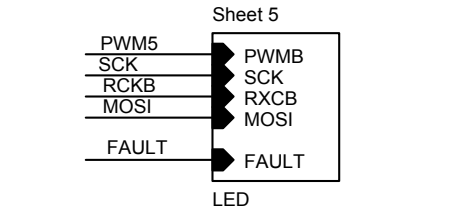
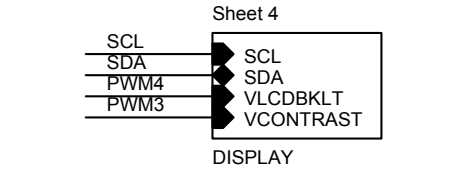
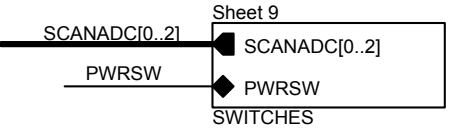
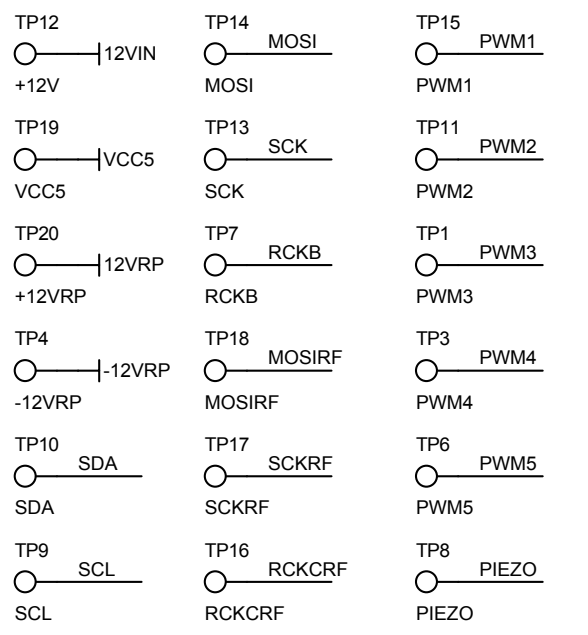
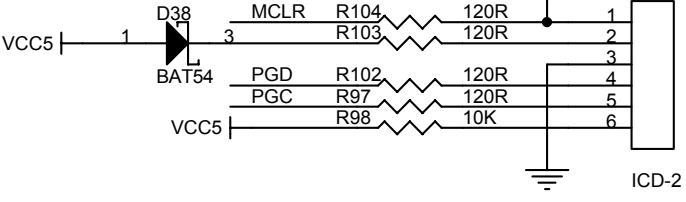
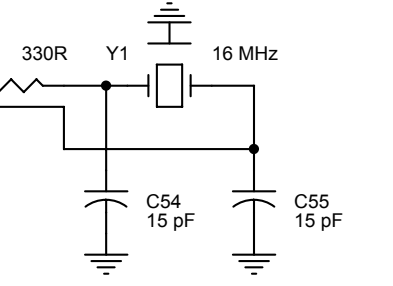
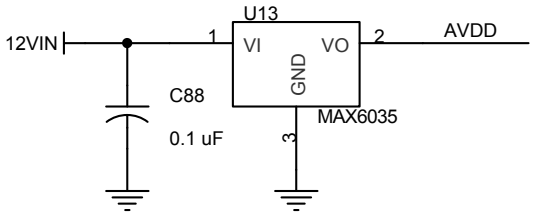
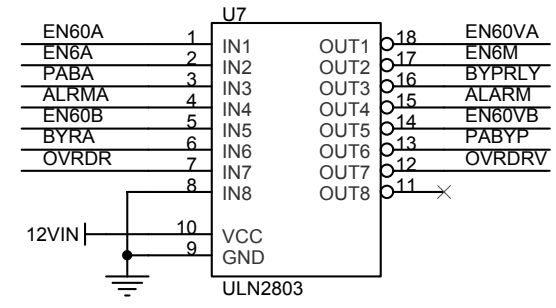
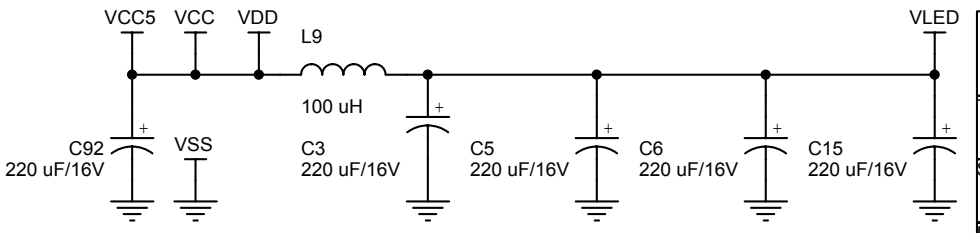
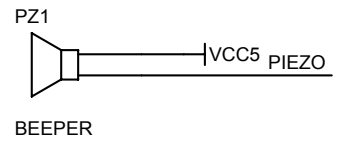
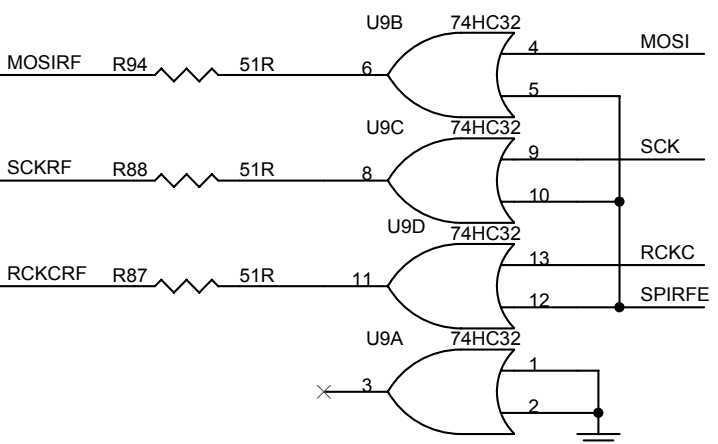
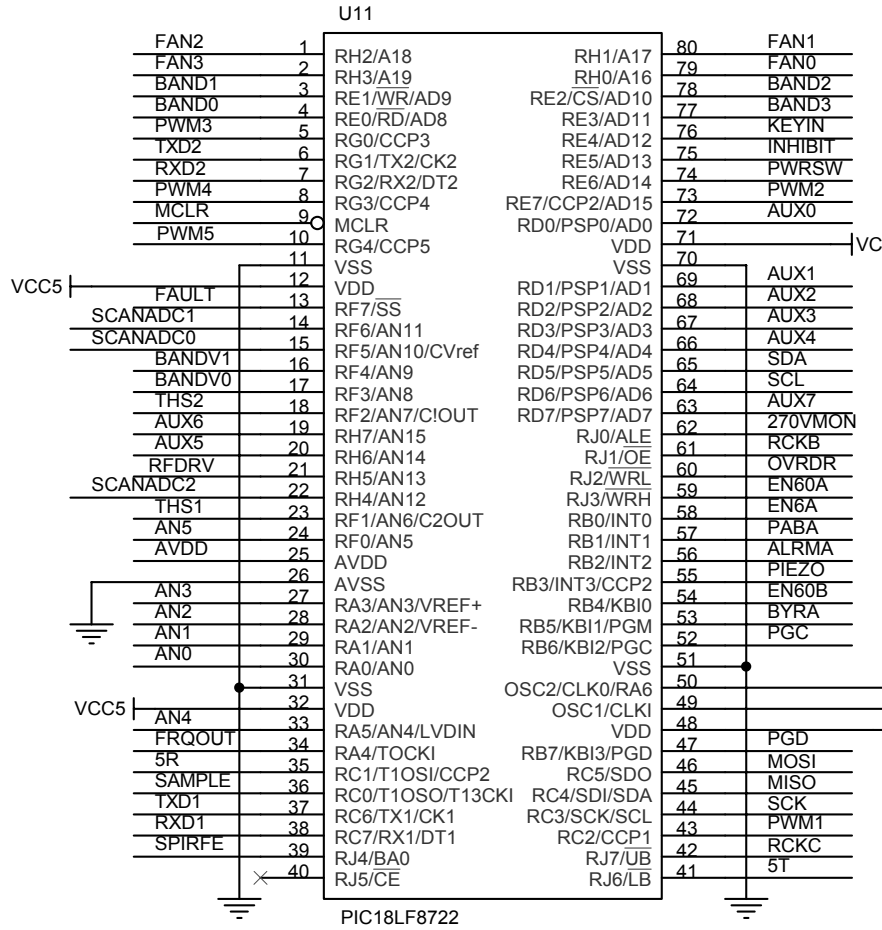
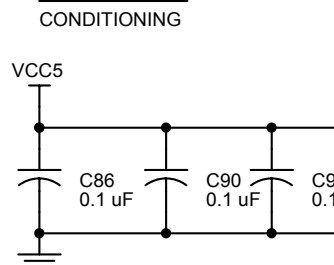
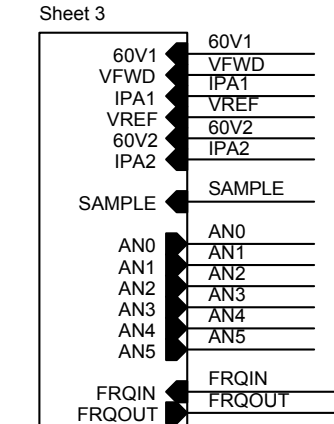
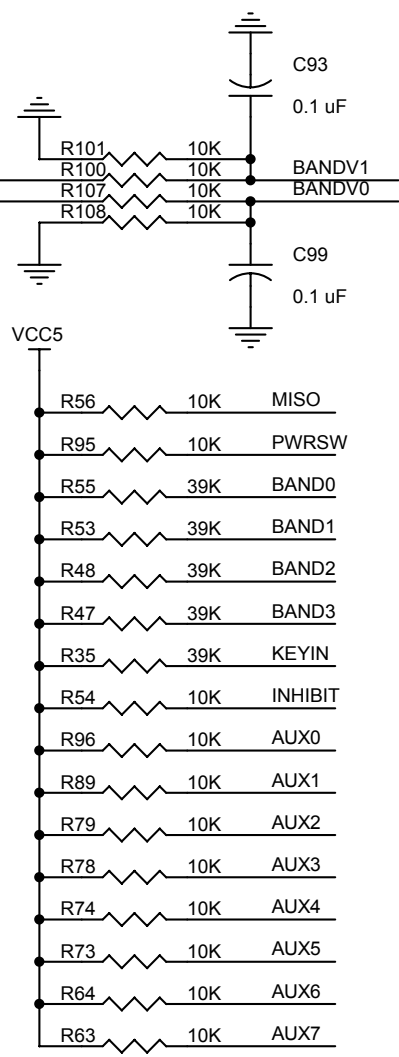
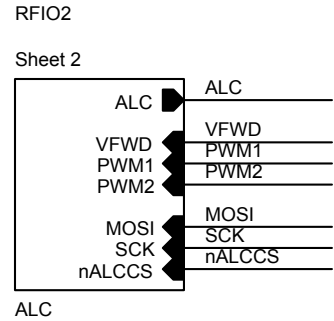
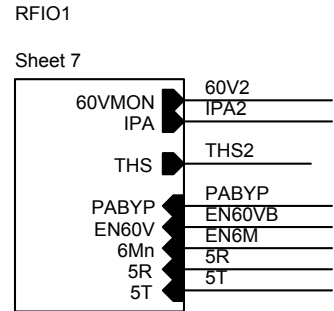
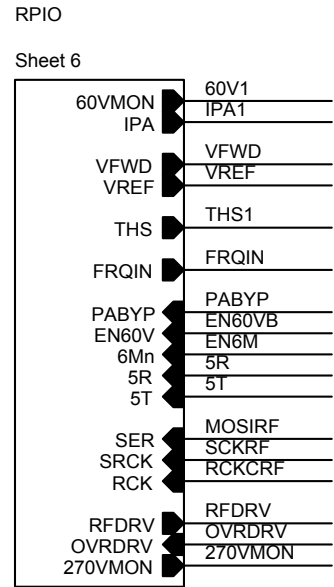
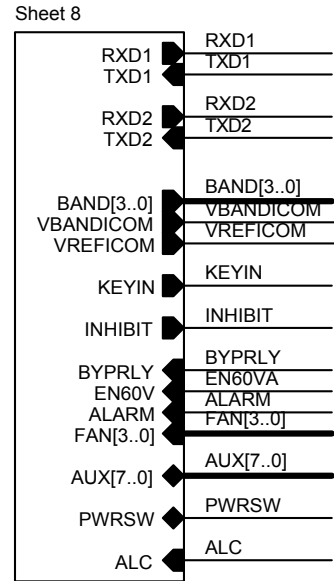

Elecrafc, Inc. Copyright (C) 2009 - 2010. L Johnson		
Title KPA500: Front Panel		
Size B	Document Number 2009110401	Rev C
Date: Friday, February 11, 2011	Sheet 1	of 9

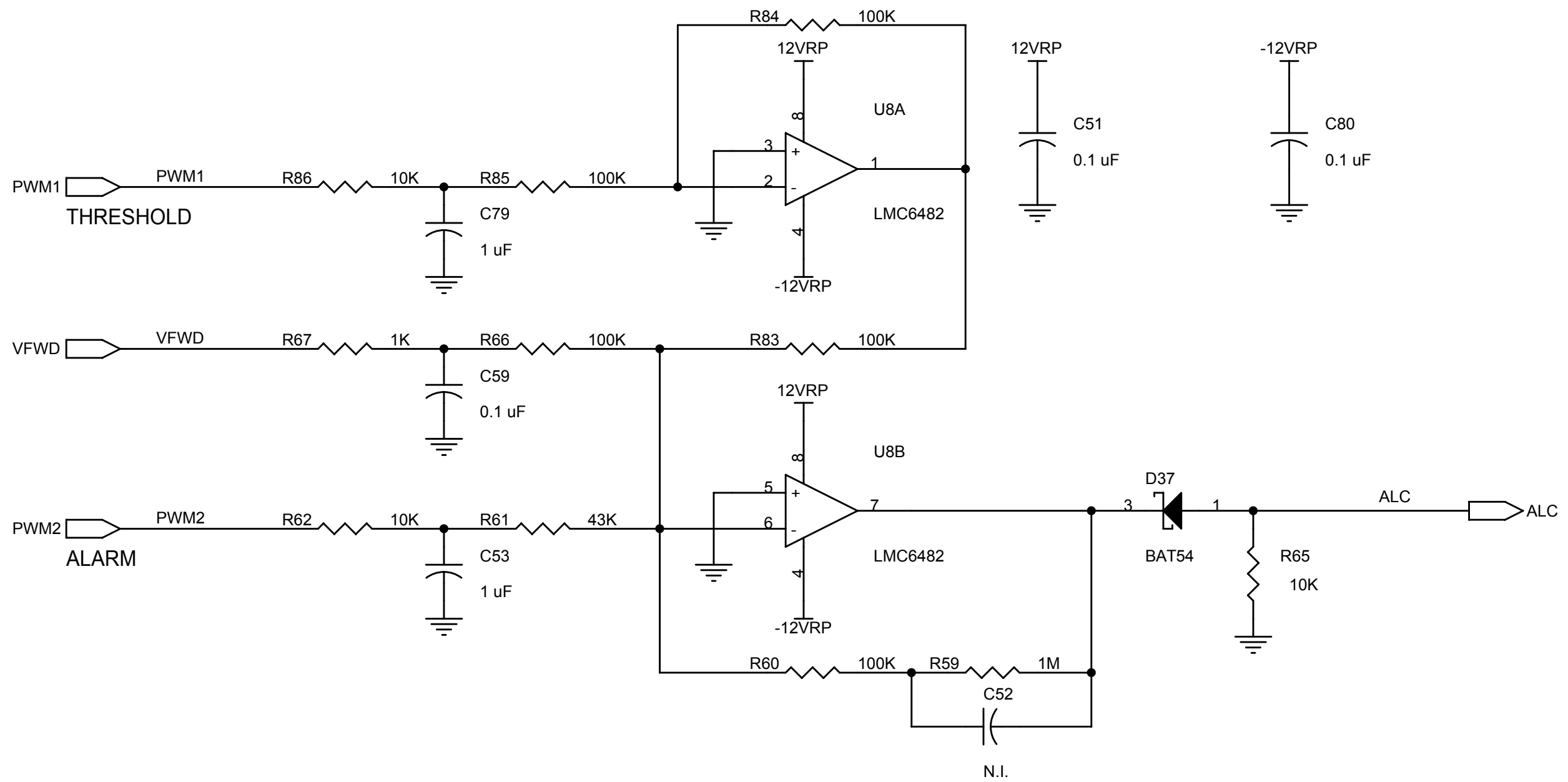

Elecraft, Inc. Copyright (C) 2009 - 2010. L Johnson		
Title KPA500 Front Panel: ALC		
Size A	Document Number 2009110401	Rev C
Date:	Friday, February 11, 2011	Sheet 2 of 9

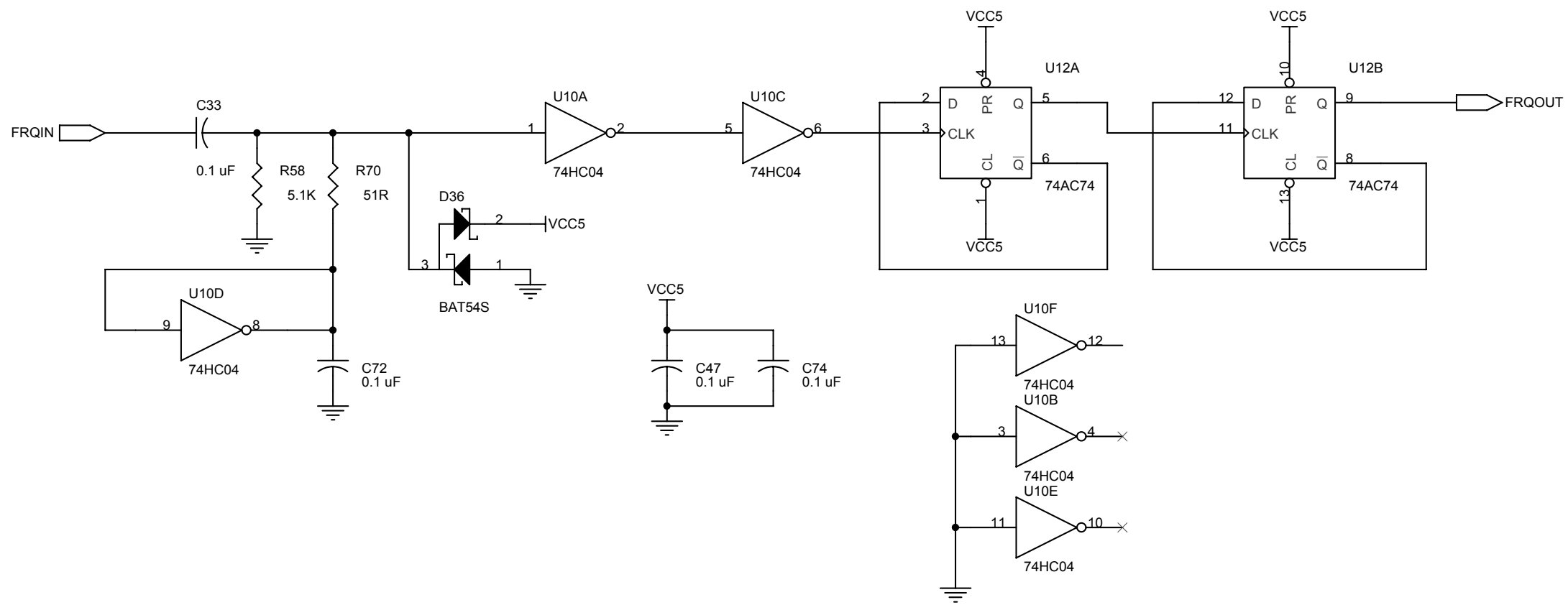
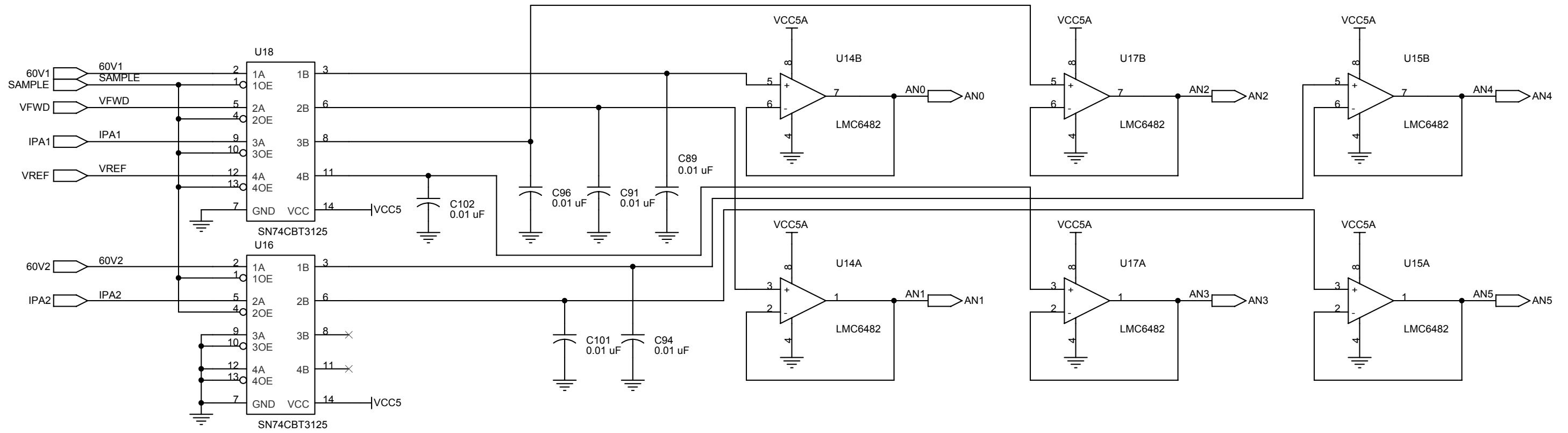

Elecrcraft, Inc. Copyright (C) 2009 - 2010. L Johnson		
Title KPA500 Front Panel: Conditioning		
Size B	Document Number 2009110401	Rev C
Date: Friday, February 11, 2011	Sheet 3	of 9

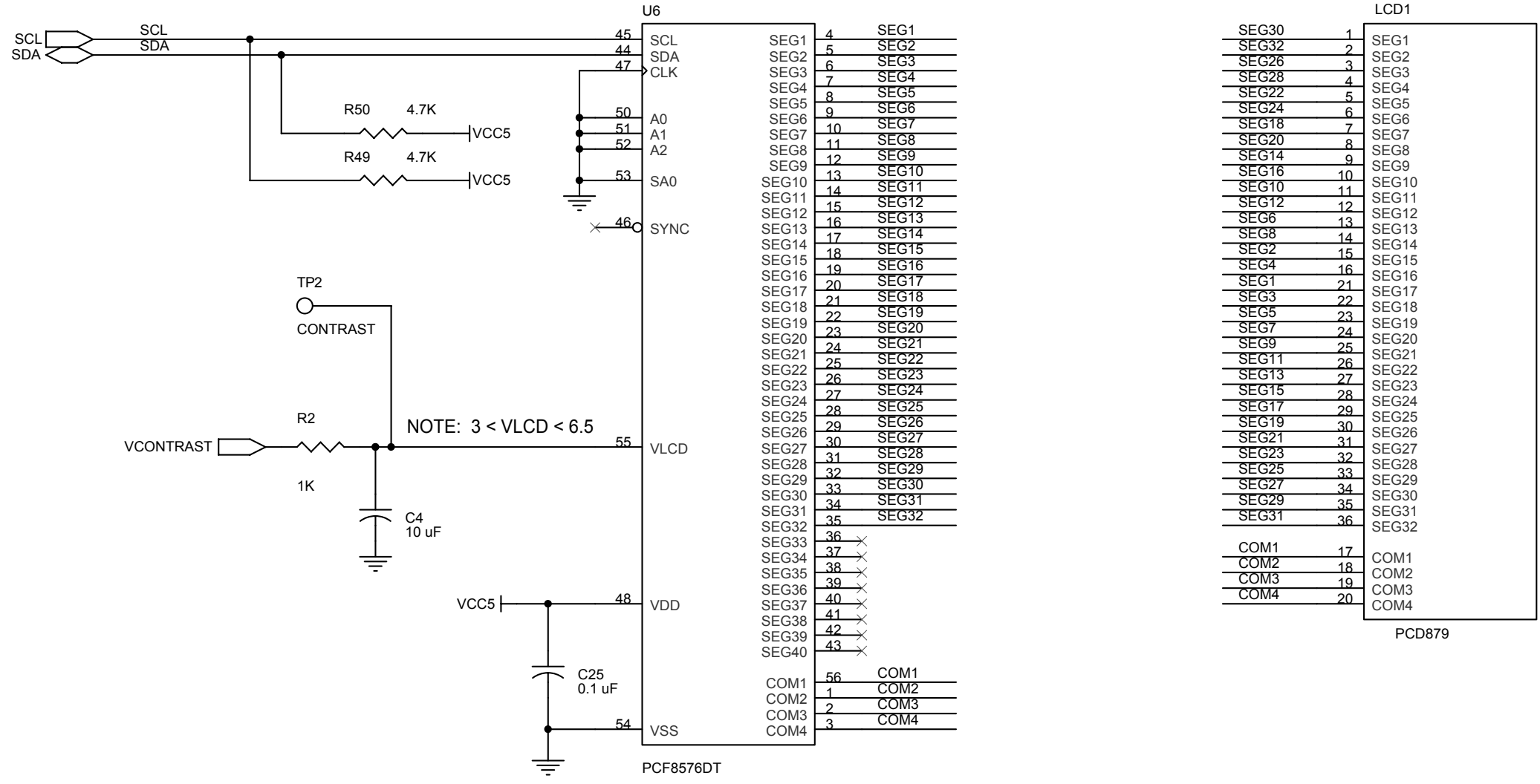

NOTE: BEZEL SPACERS

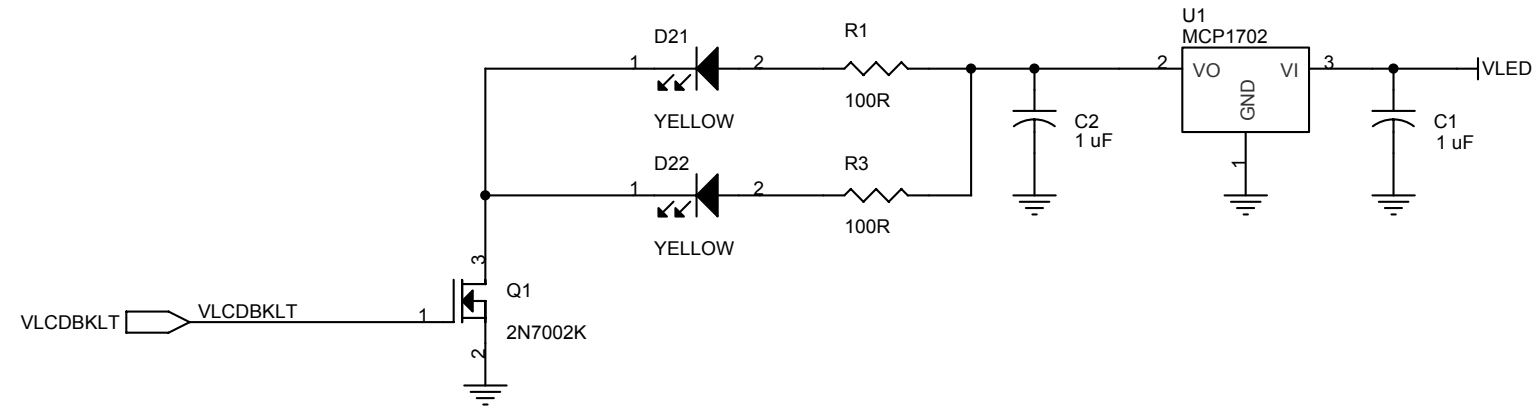
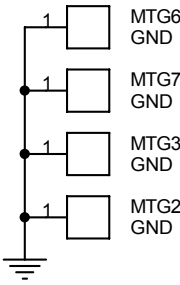

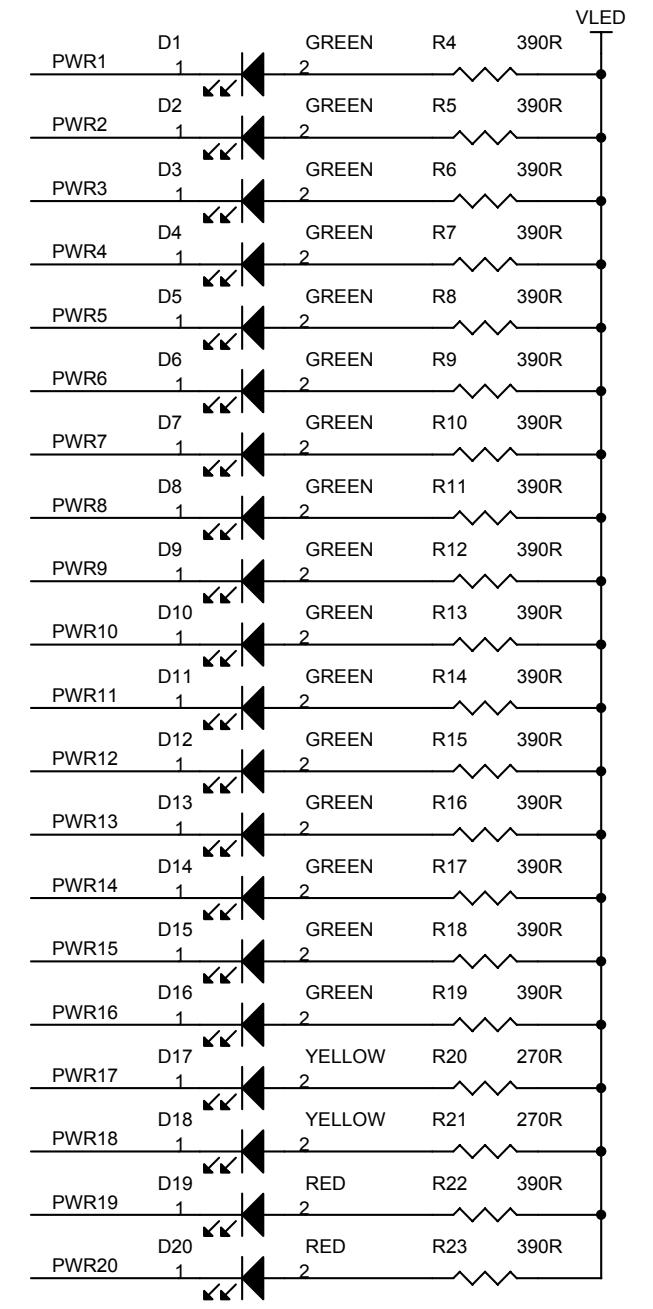
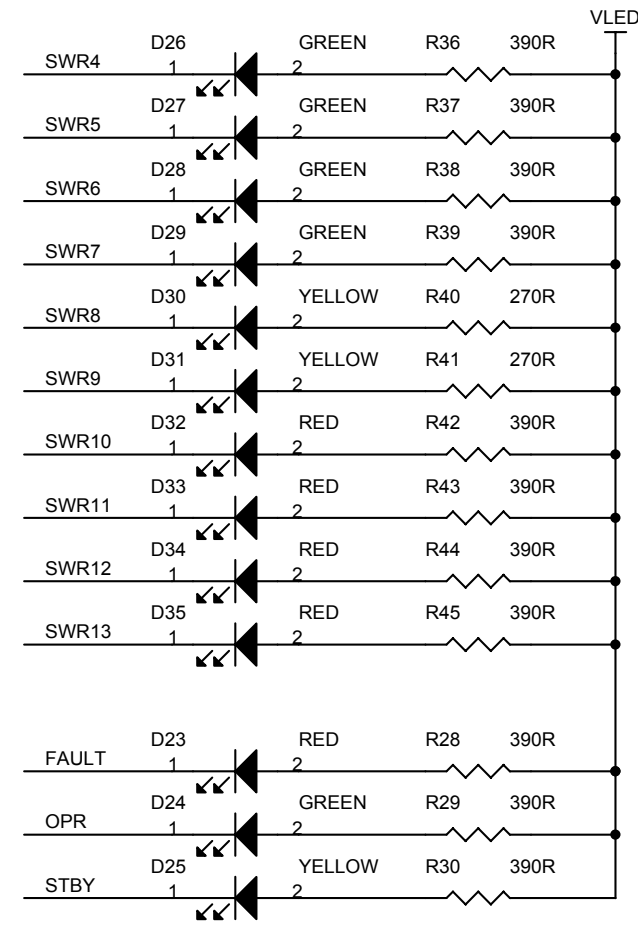
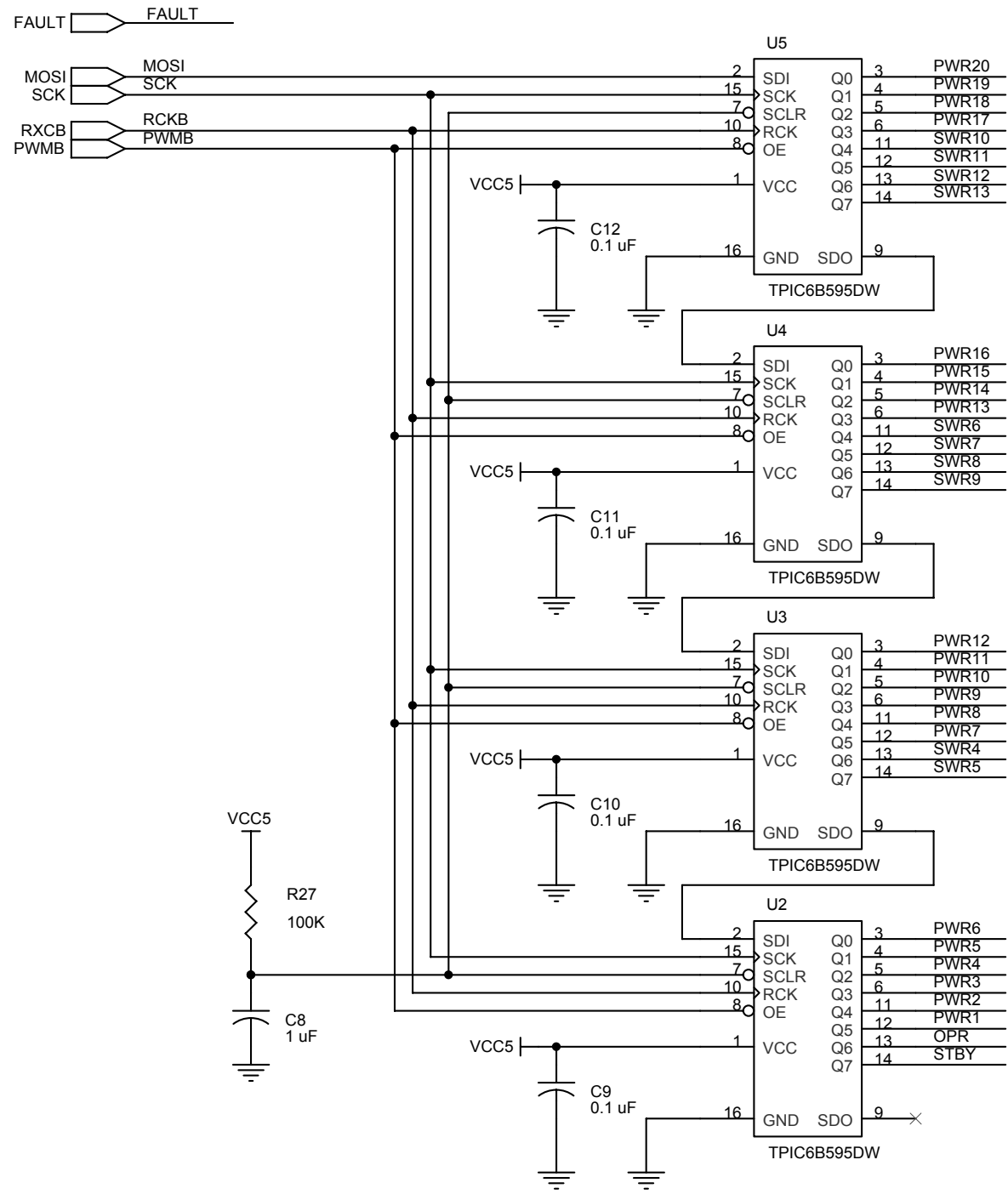

Elecrafit, Inc. Copyright (C) 2009 - 2010. L Johnson		
Title KPA500 Front Panel: LEDs		
Size B	Document Number 2009110401	Rev C
Date: Friday, February 11, 2011	Sheet 5	of 9

Pin16 is physical keying.

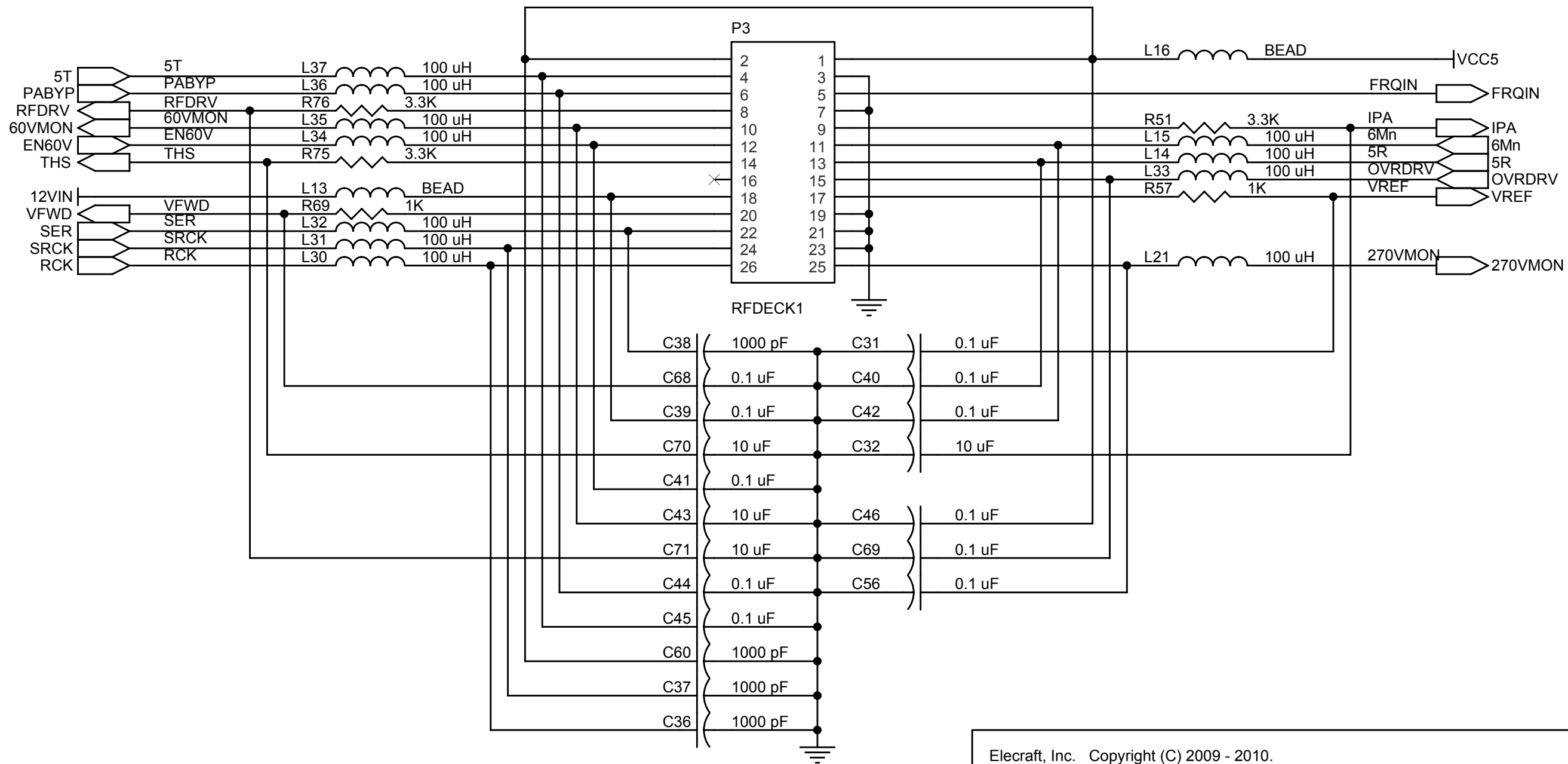

Elecraft, Inc. Copyright (C) 2009 - 2010. L Johnson		
Title KPA500 Front Panel: RF Deck 1 I/O		
Size A	Document Number 2009110401	Rev C
Date: Friday, February 11, 2011	Sheet 6	of 9

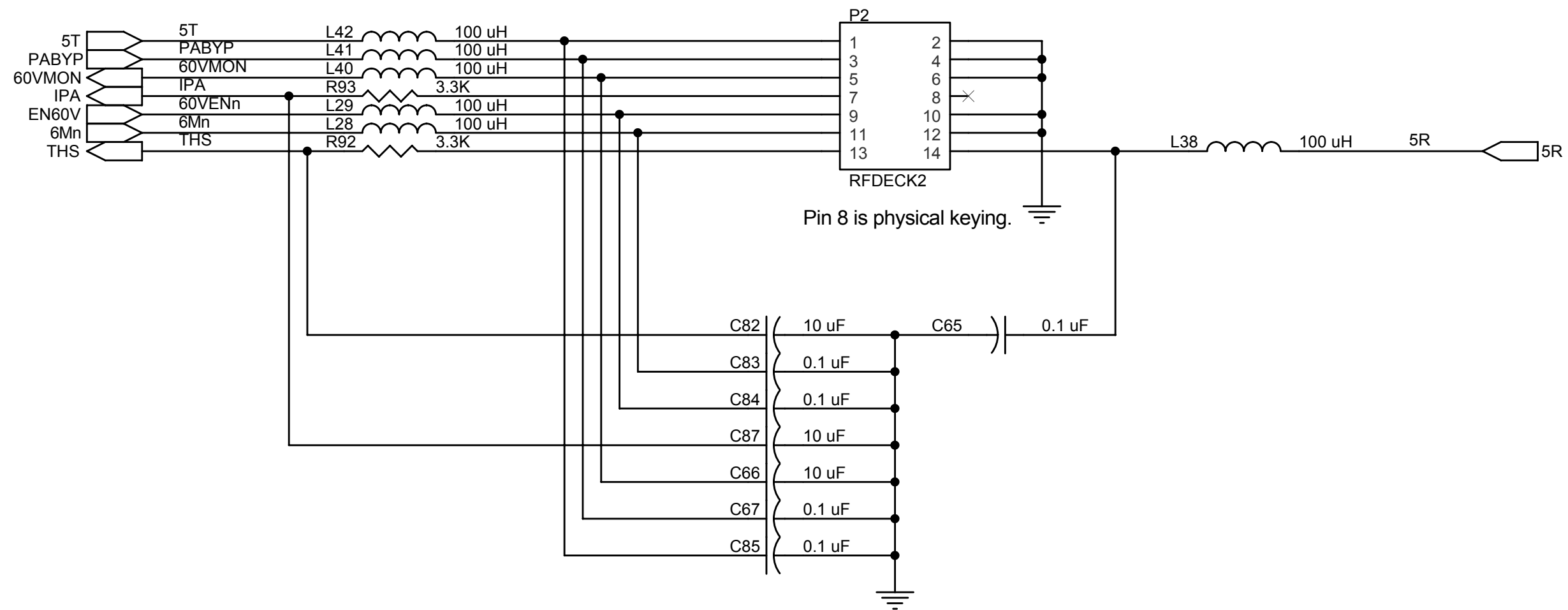

Pin 8 is physical keying.

Parts on this sheet are only placed for use with a second RF deck.

Elecraft, Inc. Copyright (C) 2009 - 2010. L Johnson		
Title KPA500 Front Panel: RF Deck 2 I/O		
Size A	Document Number 2009110401	Rev C
Date:	Friday, February 11, 2011	Sheet 7 of 9

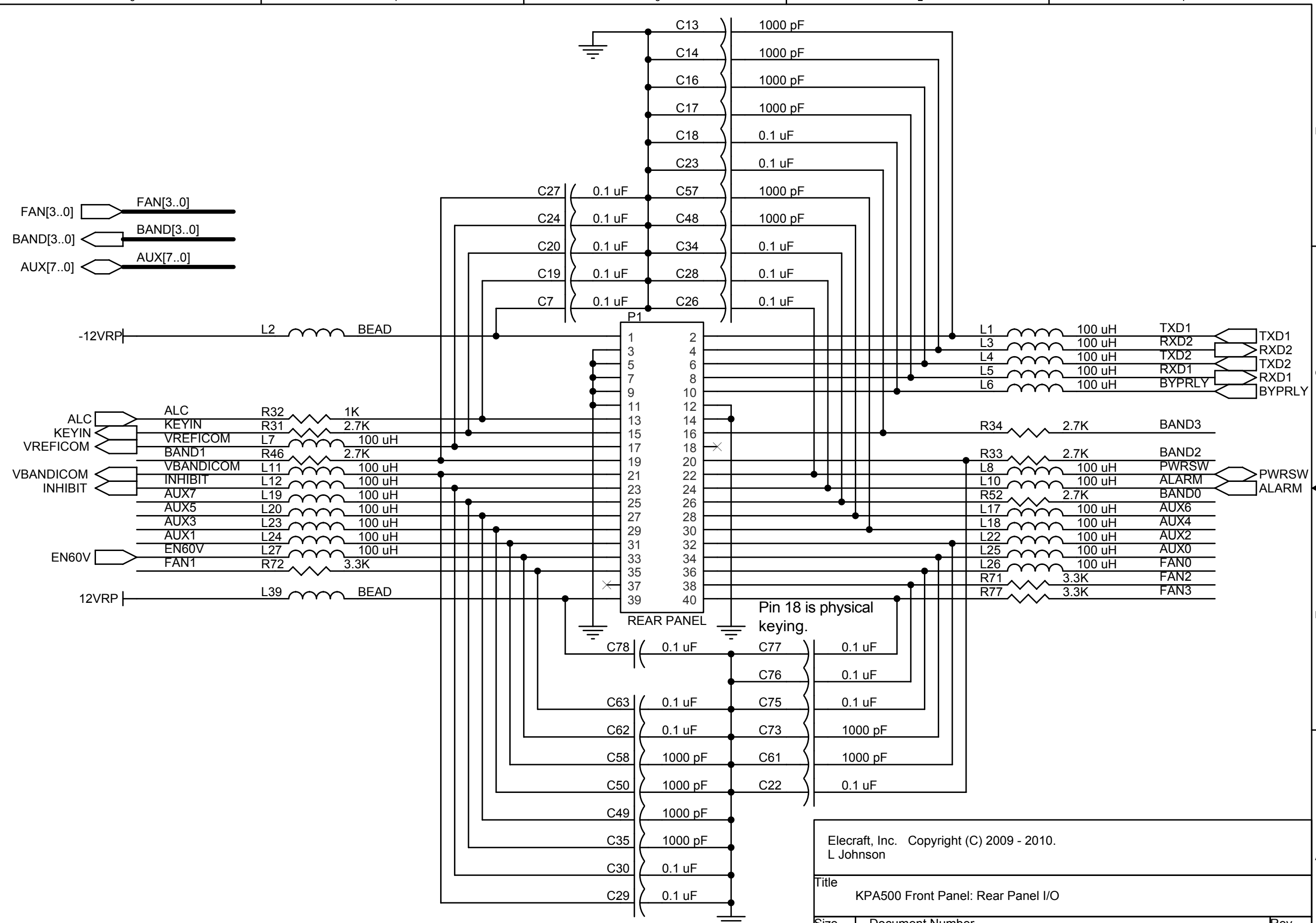

Pin 18 is physical keying.

Elecraft, Inc. Copyright (C) 2009 - 2010.
L Johnson

Title
KPA500 Front Panel: Rear Panel I/O

Size A	Document Number 2009110401	Rev C
-----------	-------------------------------	----------

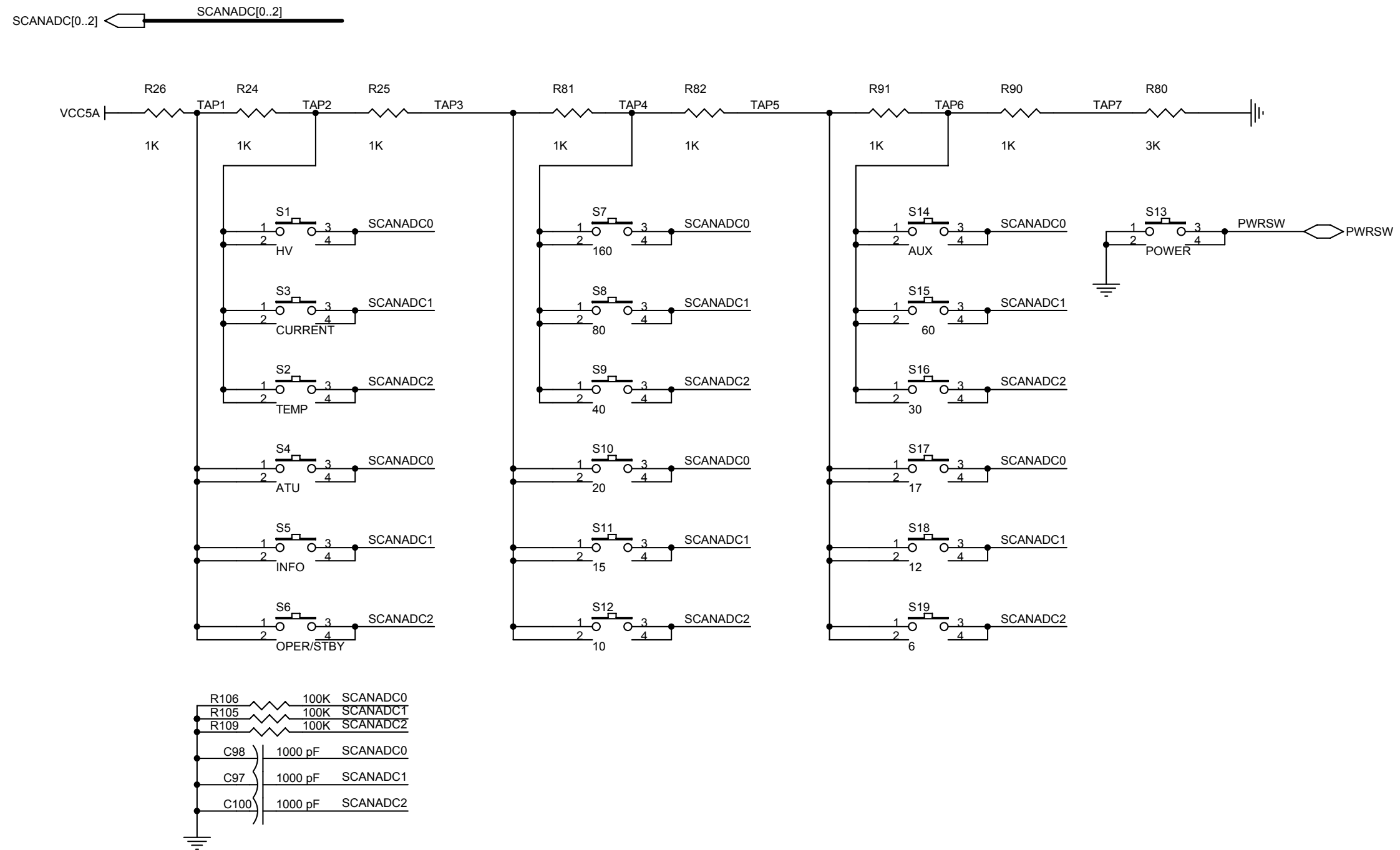

Elecrafc, Inc. Copyright (C) 2009 - 2010. L Johnson		
Title KPA500 Front Panel: Switches		
Size B	Document Number 2009110401	Rev C
Date:	Friday, February 11, 2011	Sheet 9 of 9

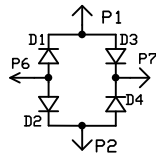

Elecraft		
Rectifier Board		
Bob Friess	Rev XA	Page 1 of 1
	8/05/2010	

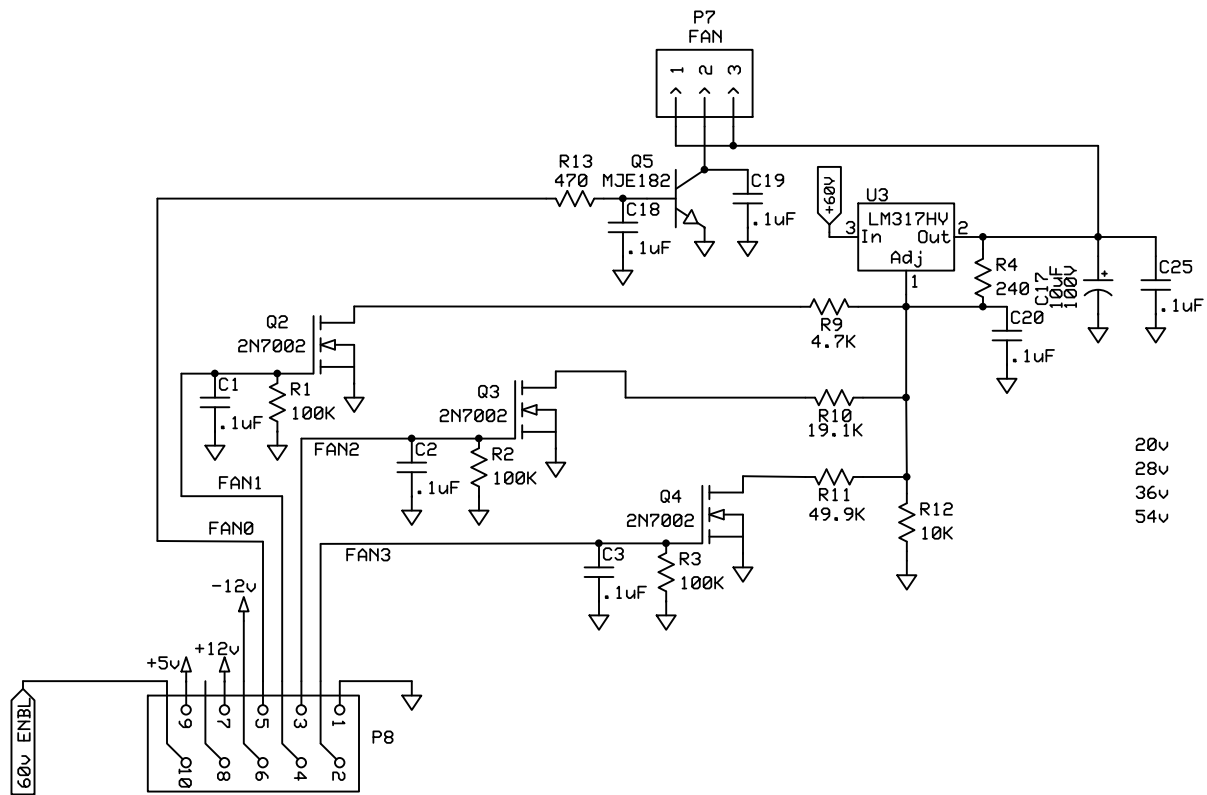

20v
28v
36v
54v